

REVISIONS			
REV	DESCRIPTION	DATE	APPROVED
A	RELEASED TO PRODUCTION	12-15-98	
B	ADD HANDLE, EXTEND FREQ TO 3GHz ECO: 15496/DMD	9-26-14	D. Downing

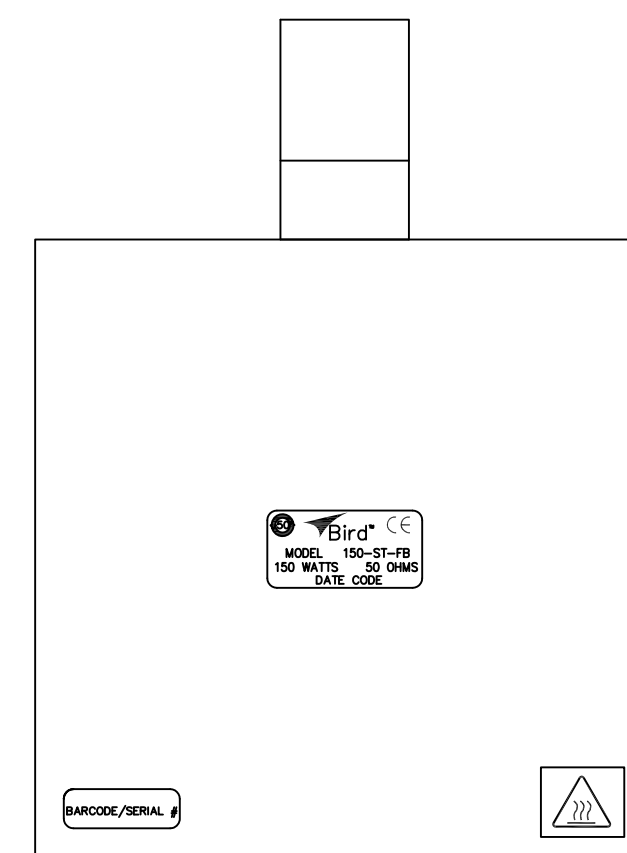

SPECIFICATIONS:
 IMPEDANCE: 50 OHMS NOMINAL
 POWER RATING: 150 CW AT 40°C
 180 CW AT 25°C
 FREQUENCY RANGE & VSWR:
 DC TO 1 GHz AT 1.10:1 MAX.
 1 GHz TO 3 GHz AT 1.25:1 MAX.
 CONNECTOR: BNC FEMALE
 OPERATING POSITION: ANY
 AMBIENT TEMPERATURE: -45°C TO +40°C
 OPERATING TEMPERATURE: -45°C TO +120°C
 HUMIDITY: 95% NON-CONDENSED
 NOMINAL SIZE: APPROX 7.40" L X 4.00" W X 5.42" H
 WEIGHT: APPROX. 5.0 LBS

MATERIALS: ALL RoHS COMPLIANT
 CONNECTOR BODY: BRASS
 HOUSING/COVER: ALUMINUM
 COOLING FIN: ALUMINUM
 CONTACT: BRASS OR BERYLLIUM COPPER
 INSULATOR: TEFLON (PTFE)
FINISH: ALL RoHS COMPLIANT
 BODY/HOUSING/COVER: TRI-METAL
 COOLING FIN: BLACK ANODIZE
 CONTACT: SILVER OR GOLD PLATED

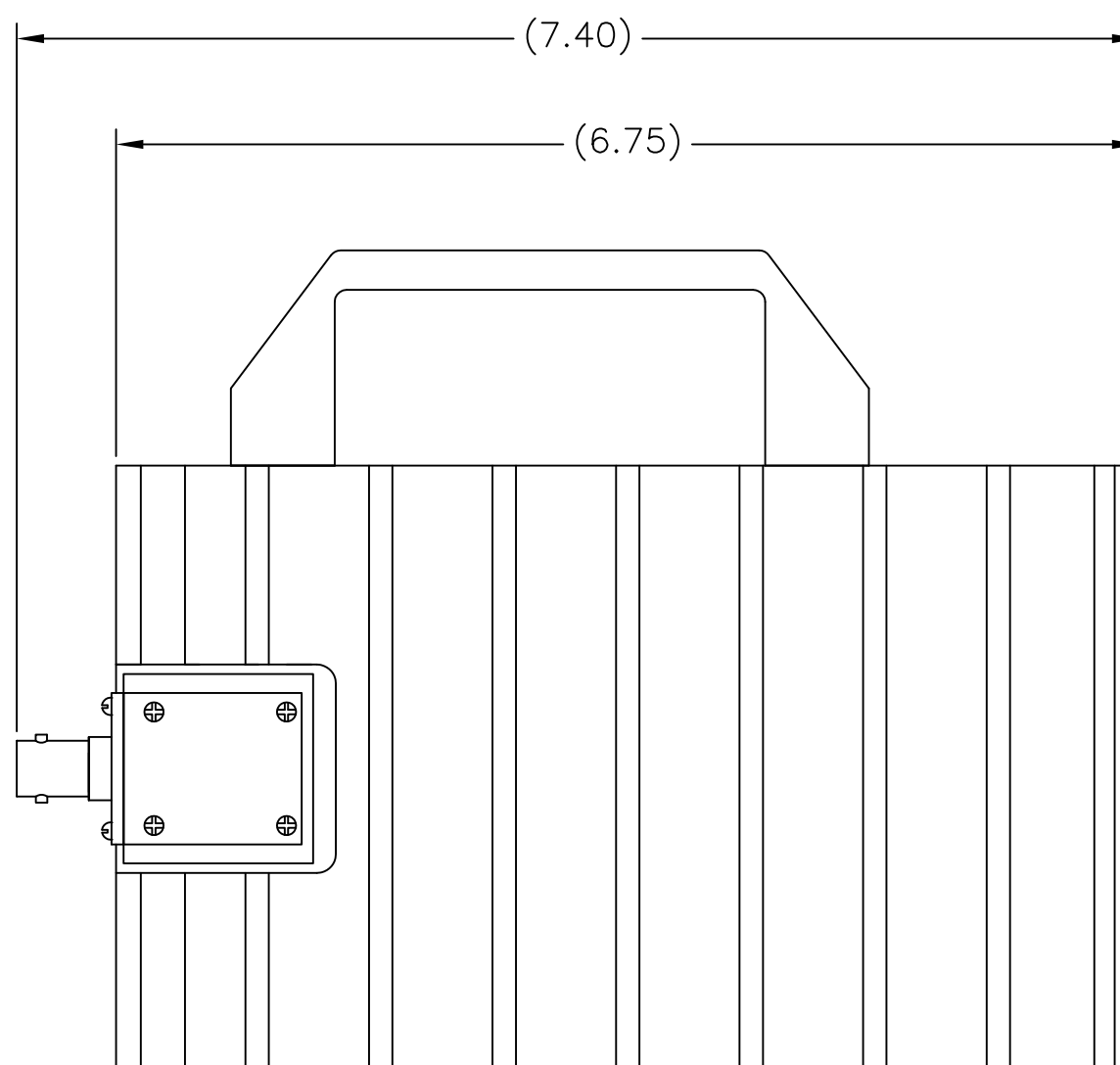
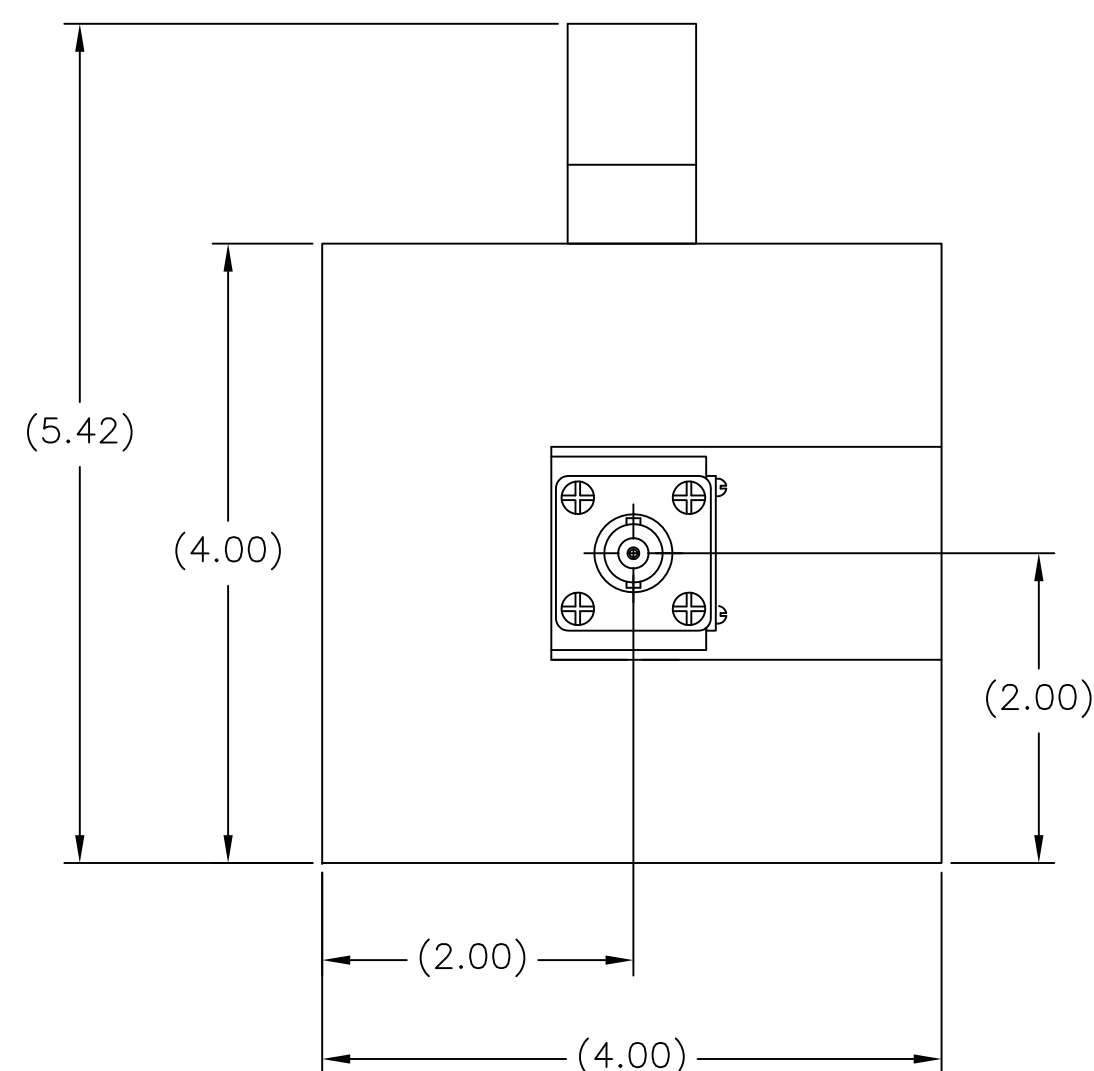
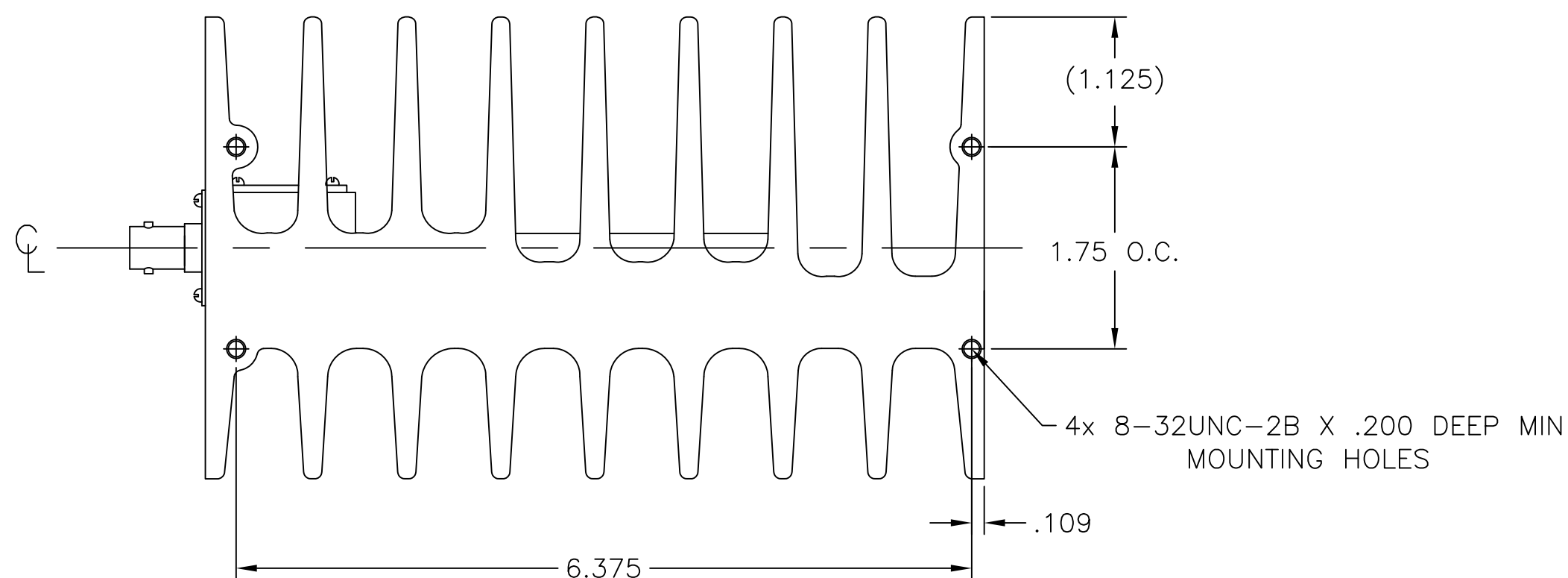

UNLESS OTHERWISE SPECIFIED DIMENSIONS ARE IN INCHES TOLERANCES ARE: FRACTIONS ±1/64 DECIMALS .xx = ±.010 .xxx = ±.005 ANGLES ±30' DO NOT SCALE DRAWING		APPROVALS DRN DMD CHK APP	DATE 12-11-97	<p>Bird Technologies</p>									
THIS DRAWING IS THE PROPERTY OF THE BIRD TECHNOLOGIES GROUP OR BIRD ELECTRONIC CORPORATION. THE DESIGNS AND SPECIFICATIONS DISCLOSED HEREON ARE PROPRIETARY AND SHALL NOT BE REPRODUCED, NOR COPIED, NOR USED AS THE BASIS FOR THE MANUFACTURE OR SALE OF APPARATUS OR DEVICES WITHOUT THEIR EXPRESS WRITTEN CONSENT.		MATERIAL [CODE]	TITLE TERMINATION, CONVECTION COOLED, BNC FEMALE, DC-3GHz, 150W										
PROJ./LIB AUTOCAD		FINISH [CODE]	<table border="1"> <tr> <td>C</td> <td>FSCM NO. 70998</td> <td>SCALE 1:1</td> <td>DWG. NO. 150-ST-FB</td> <td>REV B</td> </tr> <tr> <td colspan="2">COMM CODE LD1</td> <td colspan="3">SHEET 1 OF 1</td> </tr> </table>		C	FSCM NO. 70998	SCALE 1:1	DWG. NO. 150-ST-FB	REV B	COMM CODE LD1		SHEET 1 OF 1	
C	FSCM NO. 70998	SCALE 1:1	DWG. NO. 150-ST-FB	REV B									
COMM CODE LD1		SHEET 1 OF 1											