

REVISIONS		DWG. NO. 4240-165 OL	SHEET 1	REV C
REV	DESCRIPTION	DATE	APPROVED	
C	UPDATE PICTORIAL OF SCREWS ECO:17103/HS	6-12-20	TJS	

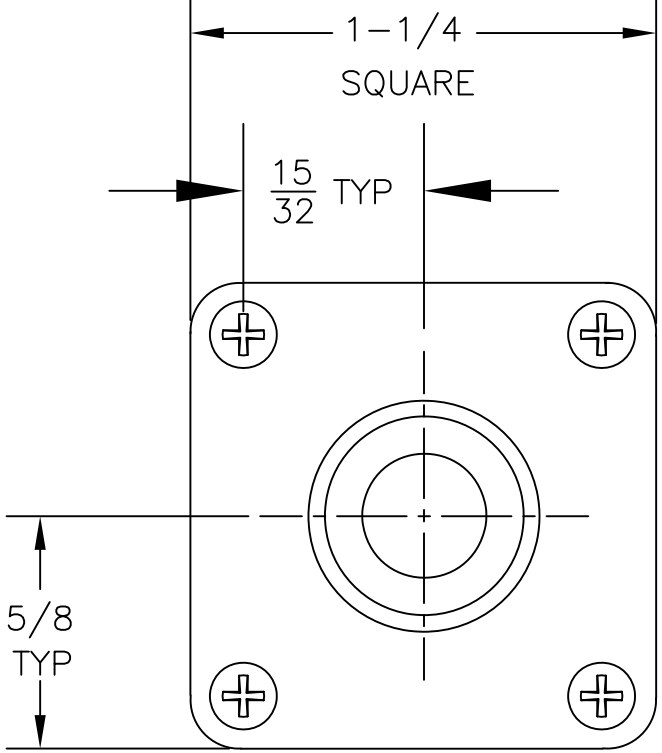
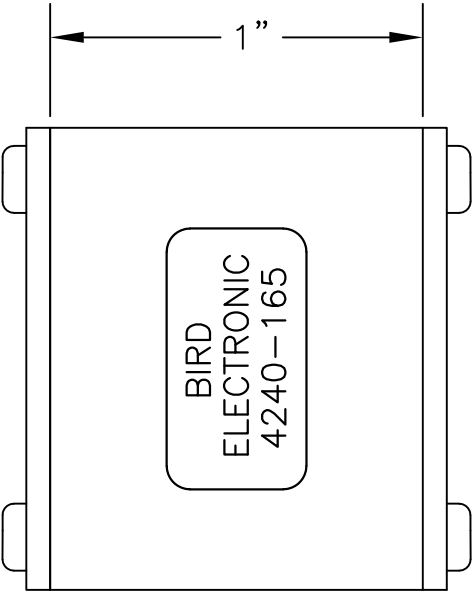

UNLESS OTHERWISE SPECIFIED DIMENSIONS ARE IN INCHES  
 TOLERANCES ARE:  
 FRACTIONS  $\pm 1/64$     DECIMALS .XX=  $\pm 0.10$   
                                  .XXX=  $\pm 0.005$   
 ANGLES  $\pm 30'$          MILLIMETERS .X=  $\pm .4$   
                                  .XX=  $\pm 1.2$   
 DO NOT SCALE DRAWING

THIS DRAWING IS THE PROPERTY OF THE BIRD TECHNOLOGIES GROUP OR BIRD ELECTRONIC CORPORATION. THE DESIGNS AND SPECIFICATIONS DISCLOSED HEREIN ARE PROPRIETARY AND SHALL NOT BE REPRODUCED, NOR COPIED, NOR USED AS THE BASIS FOR THE MANUFACTURE OR SALE OF APPARATUS OR DEVICES WITHOUT THEIR EXPRESS WRITTEN CONSENT.

	APPROVALS	DATE
DRN	D.L.A.	3-21-69
CHK	R.B.	3-21-69
APP	R.B.	3-21-69



TITLE  
 ADAPTER, Q.C. TO Q.C. CONNECTOR/OL

A	FSCM NO.	SCALE	DWG. NO.	REV
	70998	2:1	4240-165 OL	C

MATERIAL	CODE
----	
FINISH	CODE
BRIGHT NICKEL PLATE	

PROJ./LIB    AUTOCAD    SHEET    1 OF 1