

4

3

2

1

DWG. NO. OL3127-040 SHEET 1 REV E

REVISIONS			
REV	DESCRIPTION	DATE	APPROVED
C	REV. & REDRAWN PER ECN 9649 M.W.	11-30-95	
D	REVISED PER ECN 10035 B.T.	3-24-97	
E	DEL. HANDLES ECO: 15400/HS	4/3/14	TJS

D

D

C

C

B

B

A

A

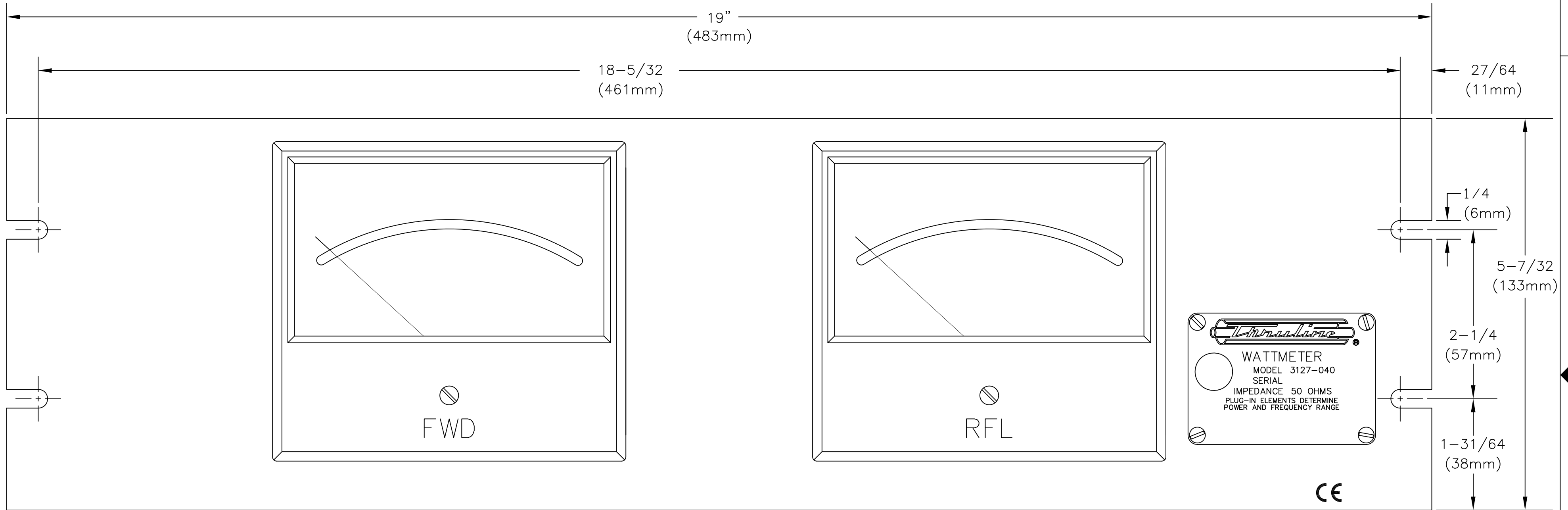

NOTE: CABLES INCLUDED, 25 FT. APPROX. (NOT SHOWN).

**SPECIFICATIONS:**

NOMINAL SIZE: 19" x 5-7/32" x 1-57/64 (483 x 133 x 48mm) 3RU  
 FINISH: GRAY PER B.E.C. DWG. 6-020  
 WEIGHT: 4 lbs. (1.8 kg)  
 COMPLIES WITH EUROPEAN STANDARDS: EN 55011 AND EN 50082-1  
 WHICH ARE IN ACCORDANCE WITH COUNCIL DIRECTIVES 89/336/EEC  
 AND 92/31/EEC. EN61010-1 WHICH IS IN ACCORDANCE WITH COUNCIL  
 DIRECTIVES 73/23/EEC AND 93/68/EEC.

DIMENSIONS HEREON ARE FOR CUSTOMER  
 CONVENIENCE AND REFERENCE ONLY.  
 TOLERANCE TO BE APPLIED ONLY WHERE  
 INDIVIDUALLY STATED ON THE RESPECTIVE  
 DIMENSION. -DO NOT SCALE DRAWING-

UNLESS OTHERWISE SPECIFIED DIMENSIONS ARE IN INCHES  
 TOLERANCES ARE:  
 FRACTIONS ±1/64 DECIMALS .xx = ±.010  
 .xxx = ±.005  
 ANGLES ±30' MILLIMETERS .x = ±.4  
 .xx = ±.12  
 DO NOT SCALE DRAWING

APPROVALS		DATE
DRN	J. WHEELER	1-31-96
CHK	A. SNYDER	7-17-96
APP		

THIS DRAWING IS THE PROPERTY OF THE BIRD  
 TECHNOLOGIES GROUP OR BIRD ELECTRONIC CORP-  
 ORATION. THE DESIGNS AND SPECIFICATIONS DISCLOSED  
 HEREON ARE PROPRIETARY AND SHALL NOT BE  
 REPRODUCED, NOR COPIED, NOR USED AS THE BASIS  
 FOR THE MANUFACTURE OR SALE OF APPARATUS OR  
 DEVICES WITHOUT THEIR EXPRESS WRITTEN CONSENT.

MATERIAL	CODE
FINISH	SEE SPECS.

**Bird Technologies**

TITLE: WATTMETER, PANEL,  
 MODEL 3127-040/OUTLINE

C	FSCM NO. 70998	SCALE FULL	DWG. NO. OL3127-040	REV E
PROJ./LIB	AUTOCAD	SHEET	1 OF 1	

4

3

2

1